

2nd May 2012

## Installation requirements for Motor Roomless Lifts (MRL) type lifts

### Purpose

To provide practical guidance on Prescribed Inspection and testing requirements for passenger lifts. To ensure lifts installed in building, which are available for passenger use, are provided with electrical supply and protective devices designed for safe operation.

### Application

These guidelines apply to lift installers, electricians and consultants in control of installations where lifts are used to convey passengers

### Background

Over the past few years the technology within the lift industry has changed and motor room less lifts (MRL) have become more common. Due to the design of these lifts the need for a traditional lift motor room is no longer required. Each lift has its protective device located in the individual lift control panel, as this panel includes protective devices it is a switchboard and shall be in an accessible position and is not located in the lift shaft.

### Definition

A safety service is defined in AS/NZS 3000:2007

#### 1.4.82 Safety service

A system or component that operates to identify an emergency, or is intended to operate during an emergency, and is primarily associated with—

- (a) the safety of persons evacuating a building; or
- (b) fire-fighting operations; or
- (c) fire suppression.

### Lift installations of one or two MRL's in new buildings.

In this instance the installer needs to run an individual supply for each lift back to the main switchboard and install a main switch for each lift. Compliance with Clause 7.2.7.2 “Wiring systems” of AS/NZS 3000:2007 would need to be maintained from the lift main switch to the protection device located on the MRL control panel.

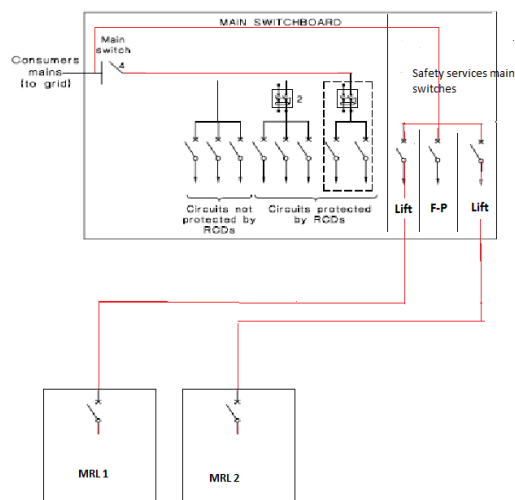

New installation 2 and under MRL's

**Lift installations with more than two MRL's in new buildings.**

In this instance ESV would consider the installation of more than two lifts as a “**safety service system**” and would allow a lift control switchboard to be installed in an accessible location and would need to be of a type that provides a two hour protection against fire or located in an area that will achieve the same two hour fire rating. The cabling and protection device located in the lift control switchboard that controls each individual MRL must discriminate and be 125% of the full load current of the MRL. Compliance with Clause 7.2.7.2 of AS/NZS 3000:2007 would need to be maintained from the lift or lift system main switch to the protection device or devices located on the MRL control panel or panels. The system would have one “Lift” main switch located on the main switchboard. Within each safety services system a switch or circuit breaker on the lift control switchboard and ESV will allow the installation of an interposing protection device between the main switchboard and the safety services which is prohibited in Clause 7.2.4.2 of AS/NZS 3000:2007.

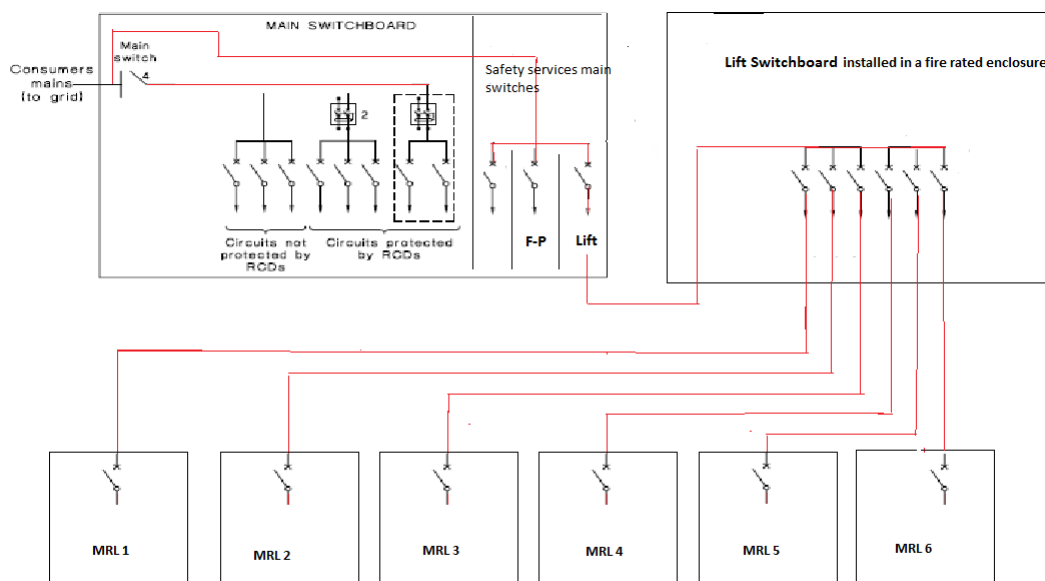

**New installation with 2 or more MRL's**

**Lift refurbishment to MRL types in existing buildings.**

In this instance ESV would consider the installation of more than two lifts as a “**safety service system**” and would allow a lift control switchboard to be installed in an accessible location and would need to be of a type that provides a two hour protection against fire or located in an area that will achieve the same two hour fire rating. The cabling and protection device located in the lift control switchboard that controls each individual MRL must discriminate and be 125% of the full load current of the MRL. Compliance with Clause 7.2.7.2 of AS/NZS 3000:2007 would need to be maintained from the lift or lift system main switch to the protection device or devices located on the MRL control panel or panels. The system would have one “Lift” main switch located on the main switchboard. Within each safety services system a switch or circuit breaker on the lift control switchboard and ESV will allow the installation of an interposing protection device between the main switchboard and the safety services which is prohibited in Clause 7.2.4.2 of AS/NZS 3000:2007.

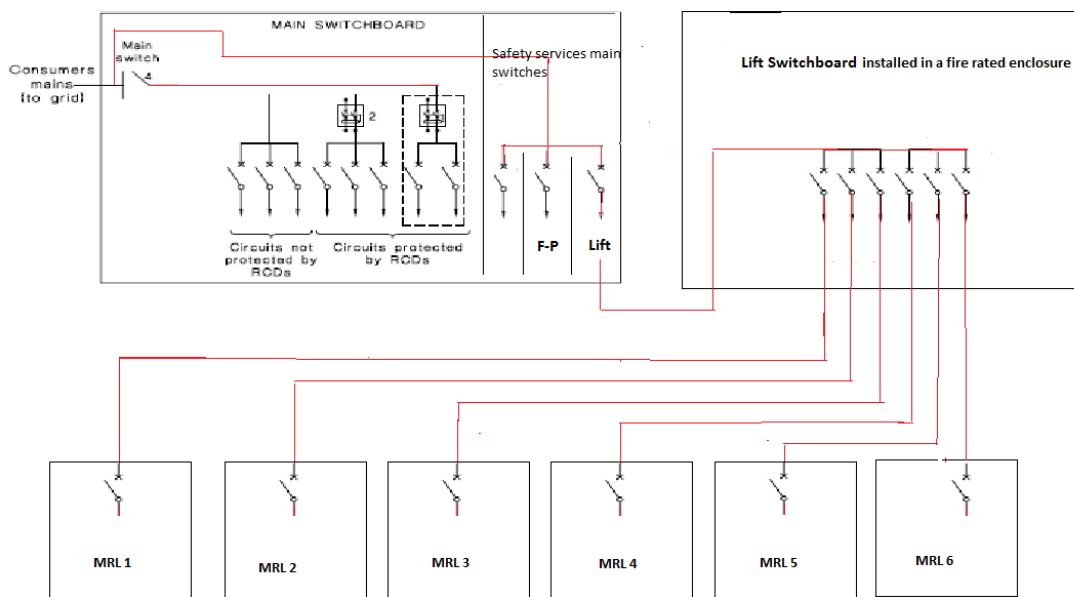

**MRL upgrade to existing installation**

**Inspection of MRL type installations.**

The Electricity Safety (Installation) Regulations 2009, r 238 (1) (i) states Prescribed electrical installation work is circuit protective devices, switchgear, controlgear, wiring systems and accessories installed to provide control and protection of passenger lifts. This regulation requires a prescribed inspection from the lift or system main switch to the protective device at the MRL control panel.